

SECTION A-A
SCALE 1/2" = 1'-0"

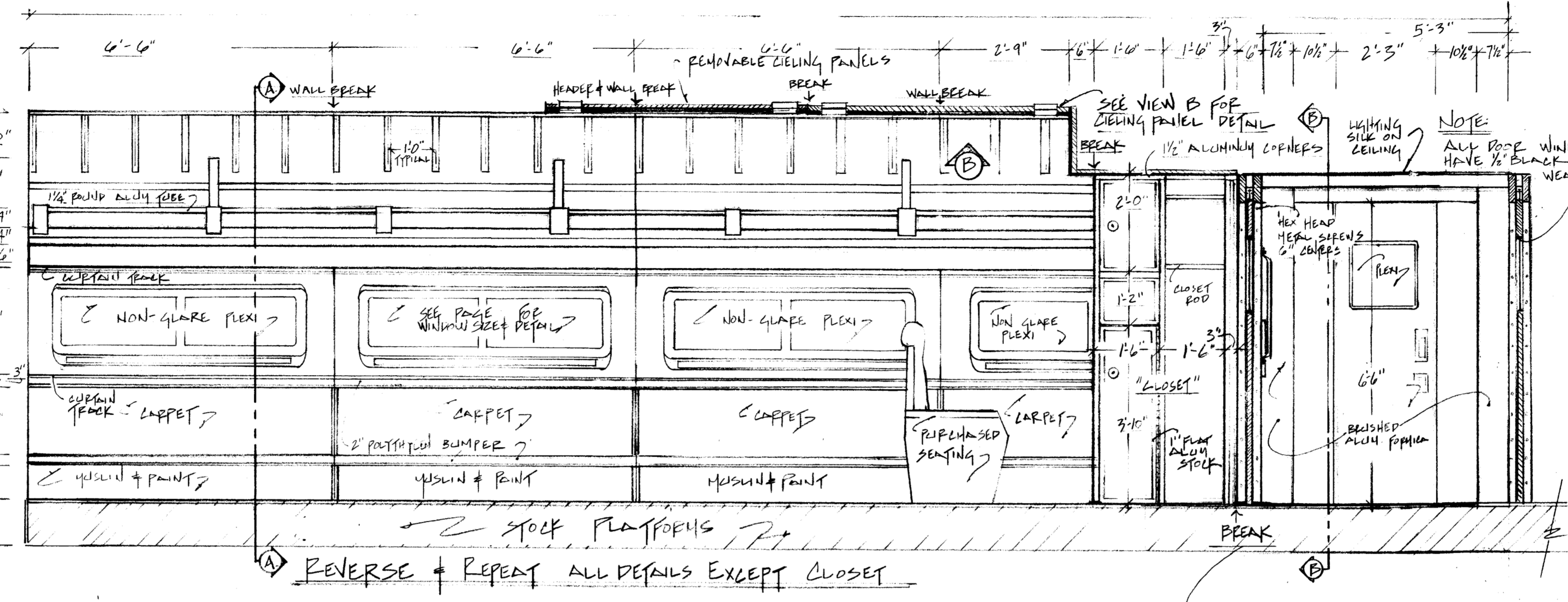

ELEVATION
SCALE 1/2" = 1'-0"

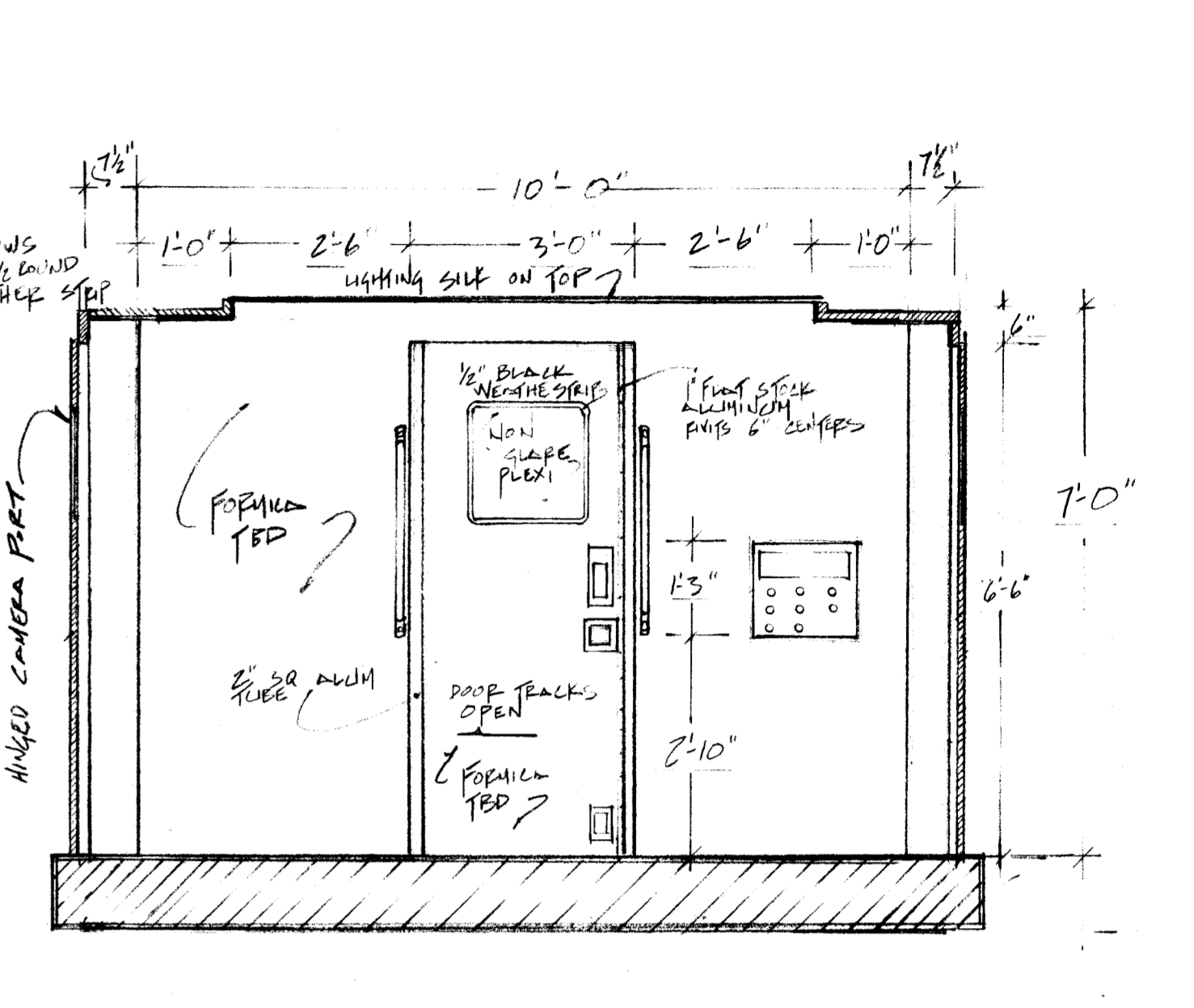

SECTION B-B
SCALE 1/2" = 1'-0"

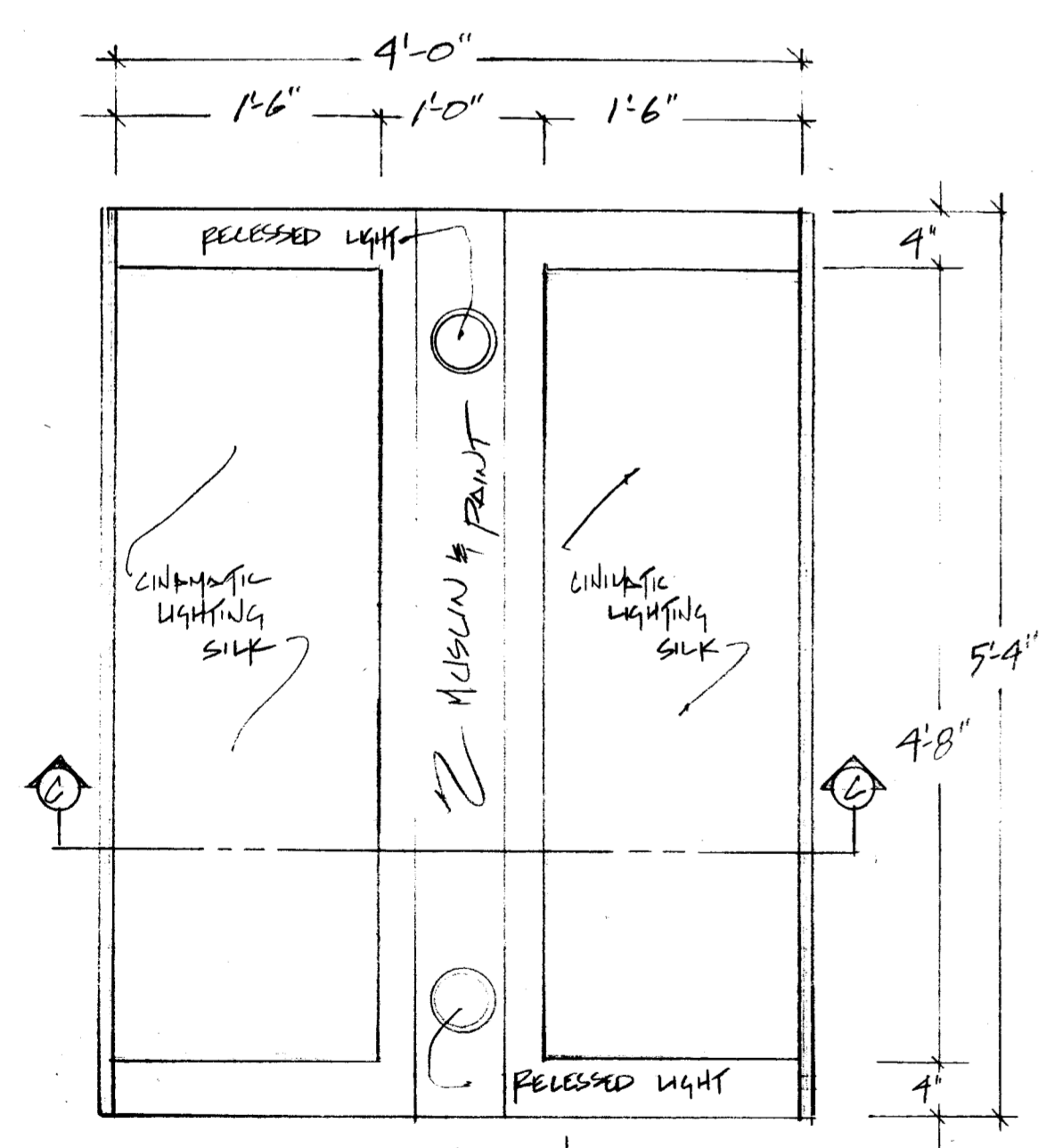

ELEVATION

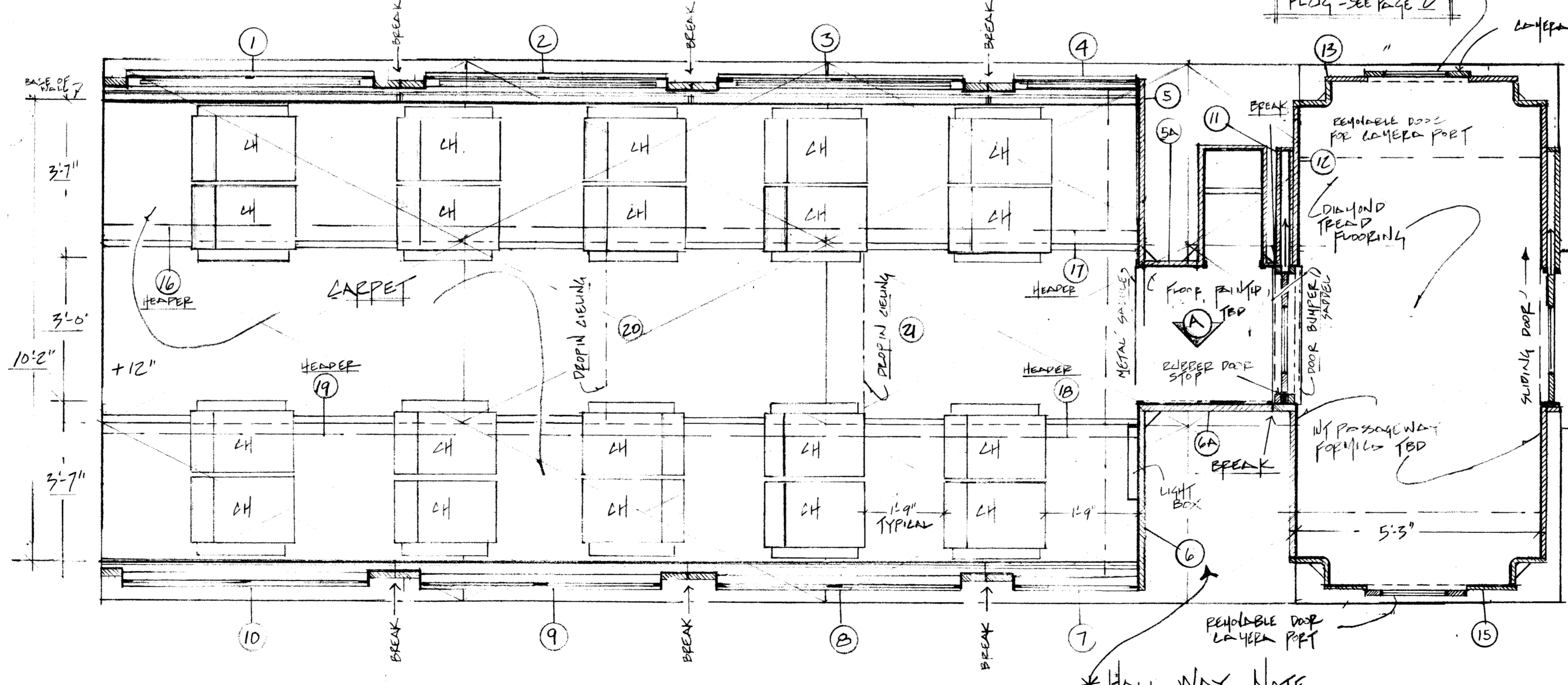

PLAN
SCALE 1/2" = 1'-0"

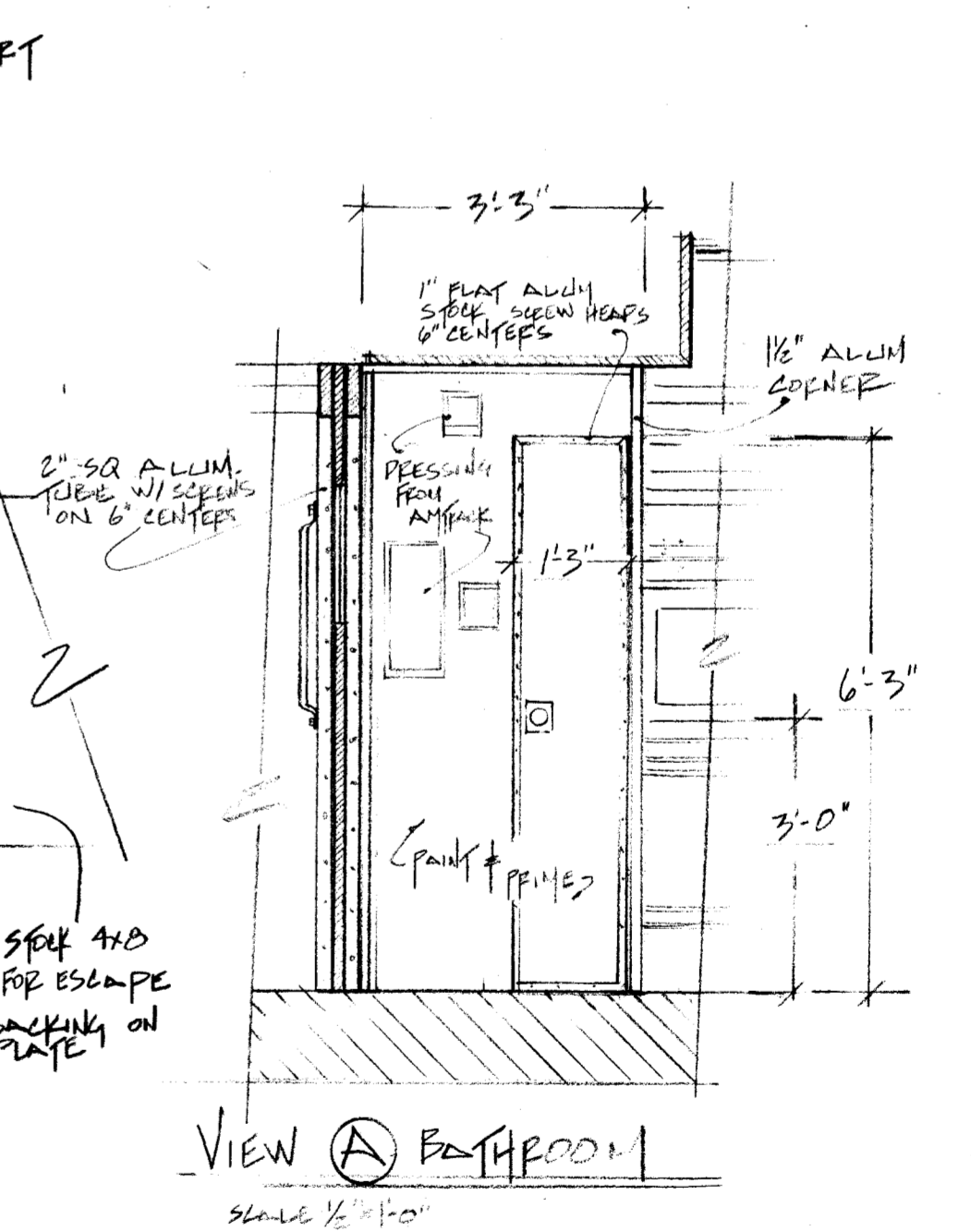

VIEW (A) BATHROOM
SCALE 1/2" = 1'-0"

*HALLWAY NOTE
- DUE TO SCRIPT CHANGE HALLWAY
5' 6" PLANT OPPOSITE AS DRAWN

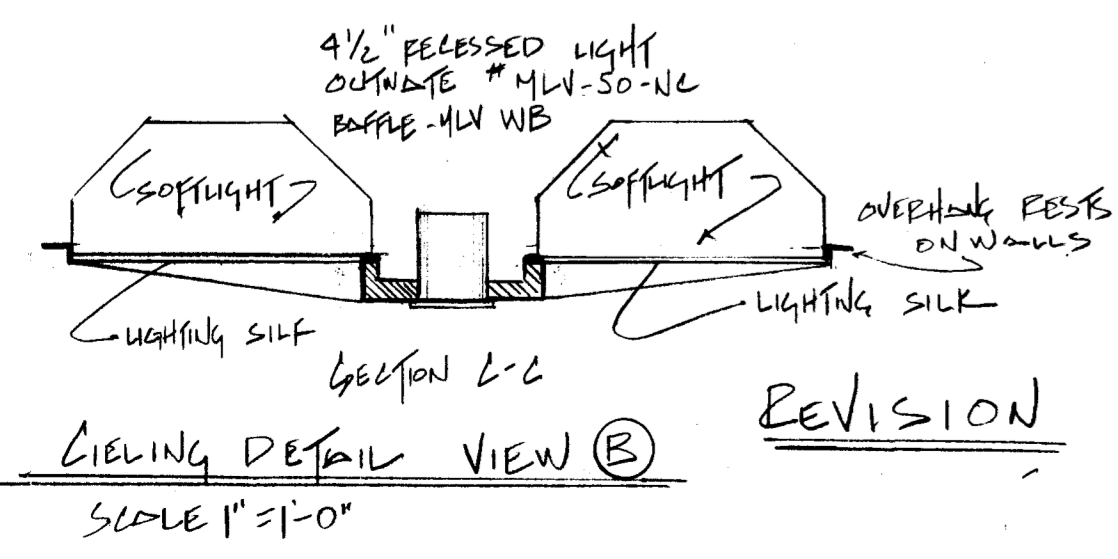

CEILING DETAIL VIEW (B)
SCALE 1" = 1'-0"

REVISION

REVISED

UNION STAMP 	AMERICAN BROADCASTING COMPANIES abc		DRAWING NO.
	PROD.:	ONE LIFE TO LIVE	STUDIO 17
	SET:	PASSENGER TRAIN INT.	
	SCALE:	1/2" = 1'-0" + NOTED	DEL. DATE: 3/31/00
	DRAWN: DATE: 2/18/00	DESIGNER: ROGER MOONEY	PROD. DATE:
S D ROE SCENIC DESIGNER SIGNATURE:	DRAFTSMAN: H O PAFFER		OF 2

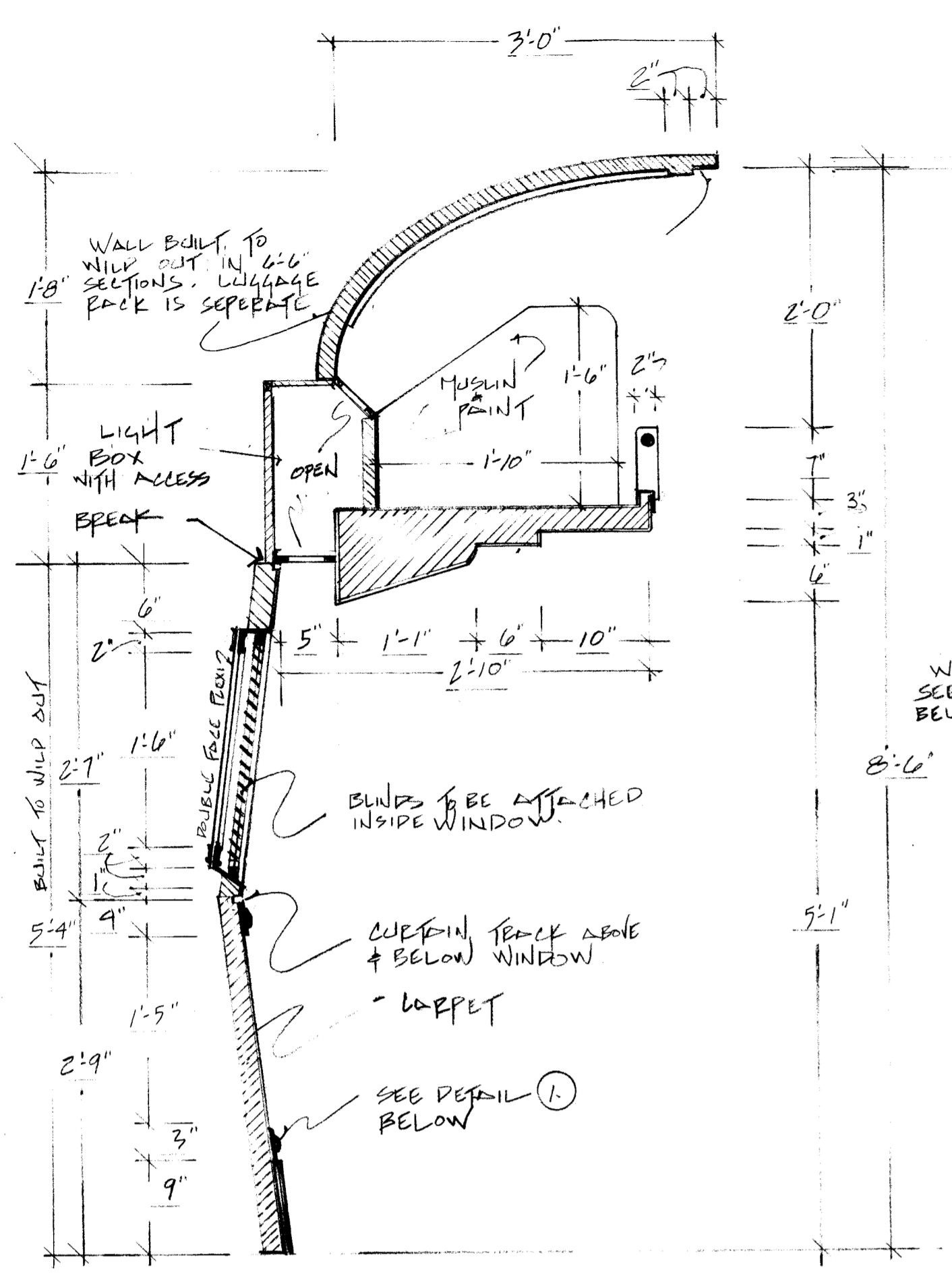

SECTION A-A
SCALE 1/2"=1'-0"

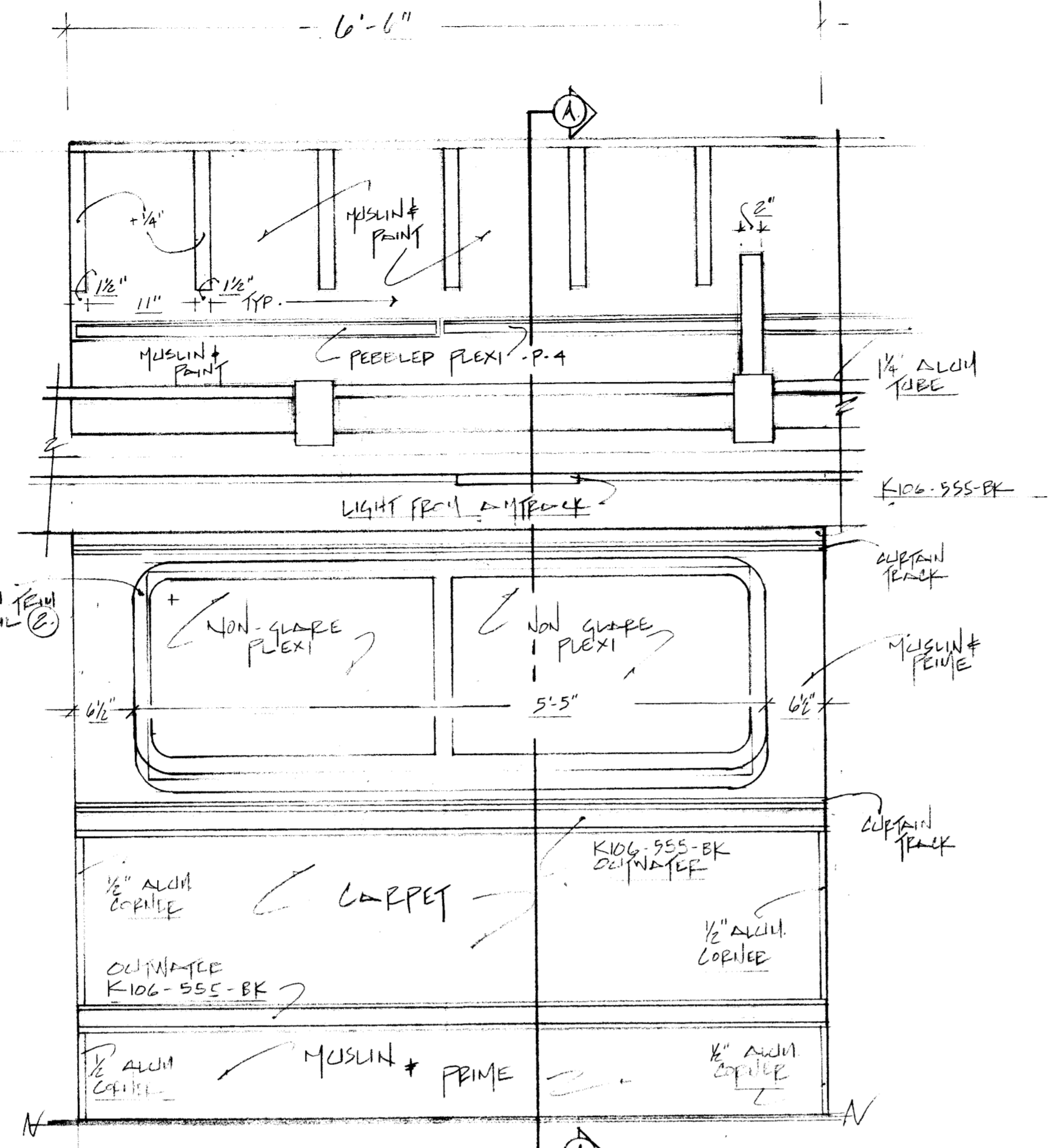

ELEVATION
SCALE 1"=1'-0"
REPEAT DETAILS FOR ALL WALLS

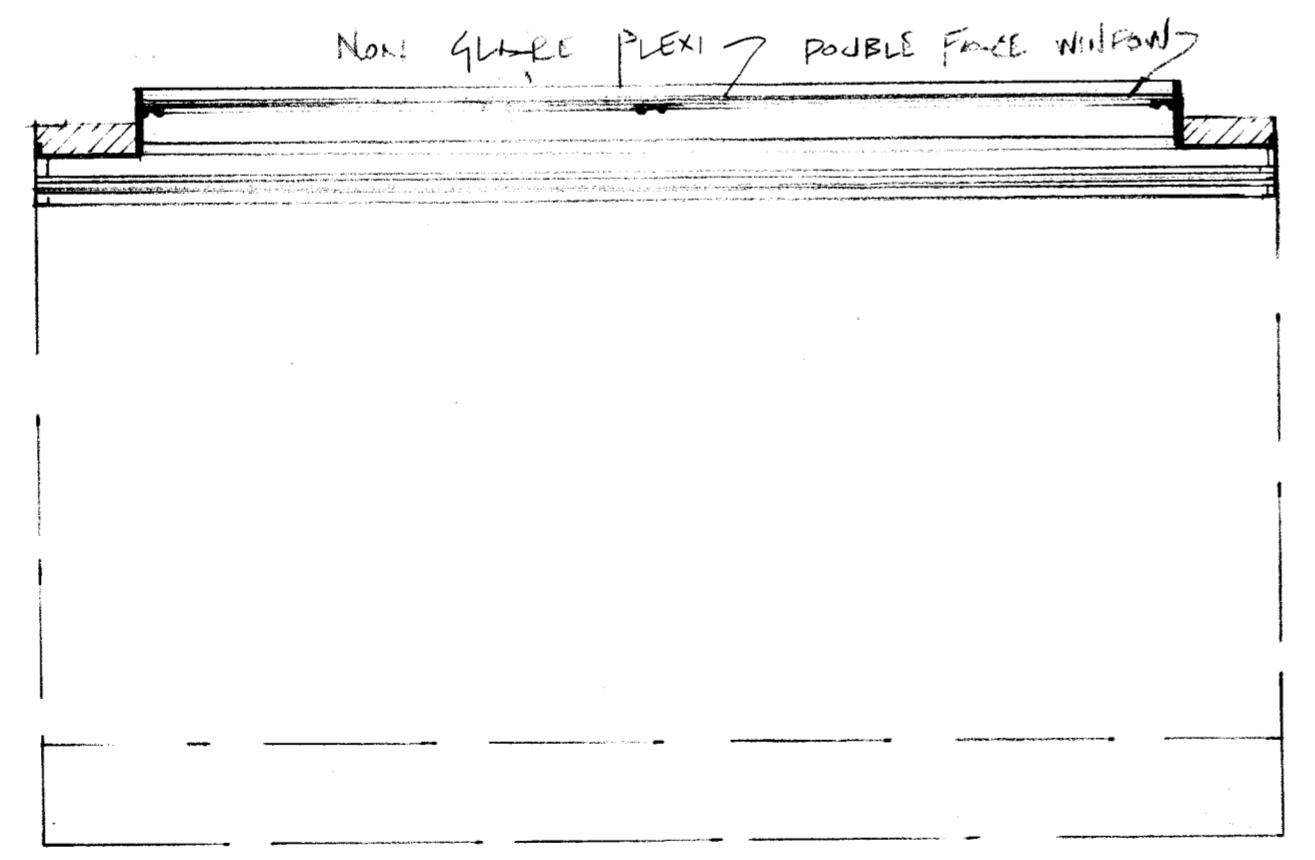

PLAN
SCALE 1"=1'-0"

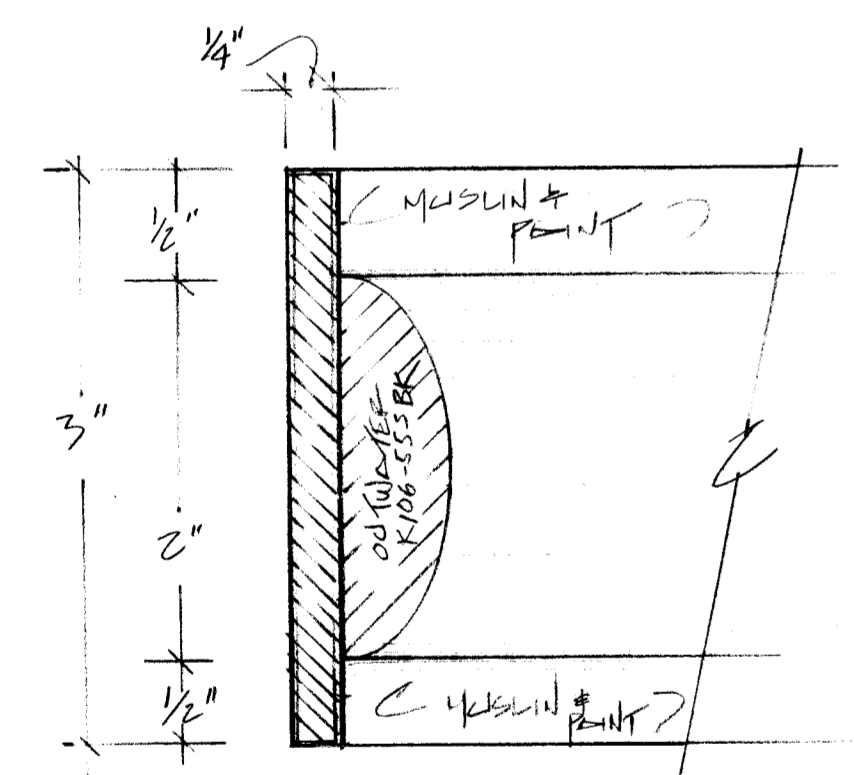

WALL TRIM ①
SCALE = FULL

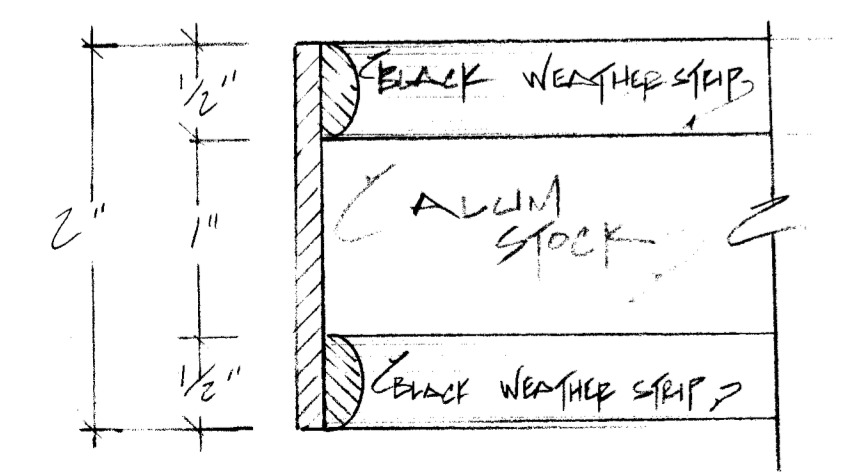

WINDOW TRIM ②
SCALE = FULL

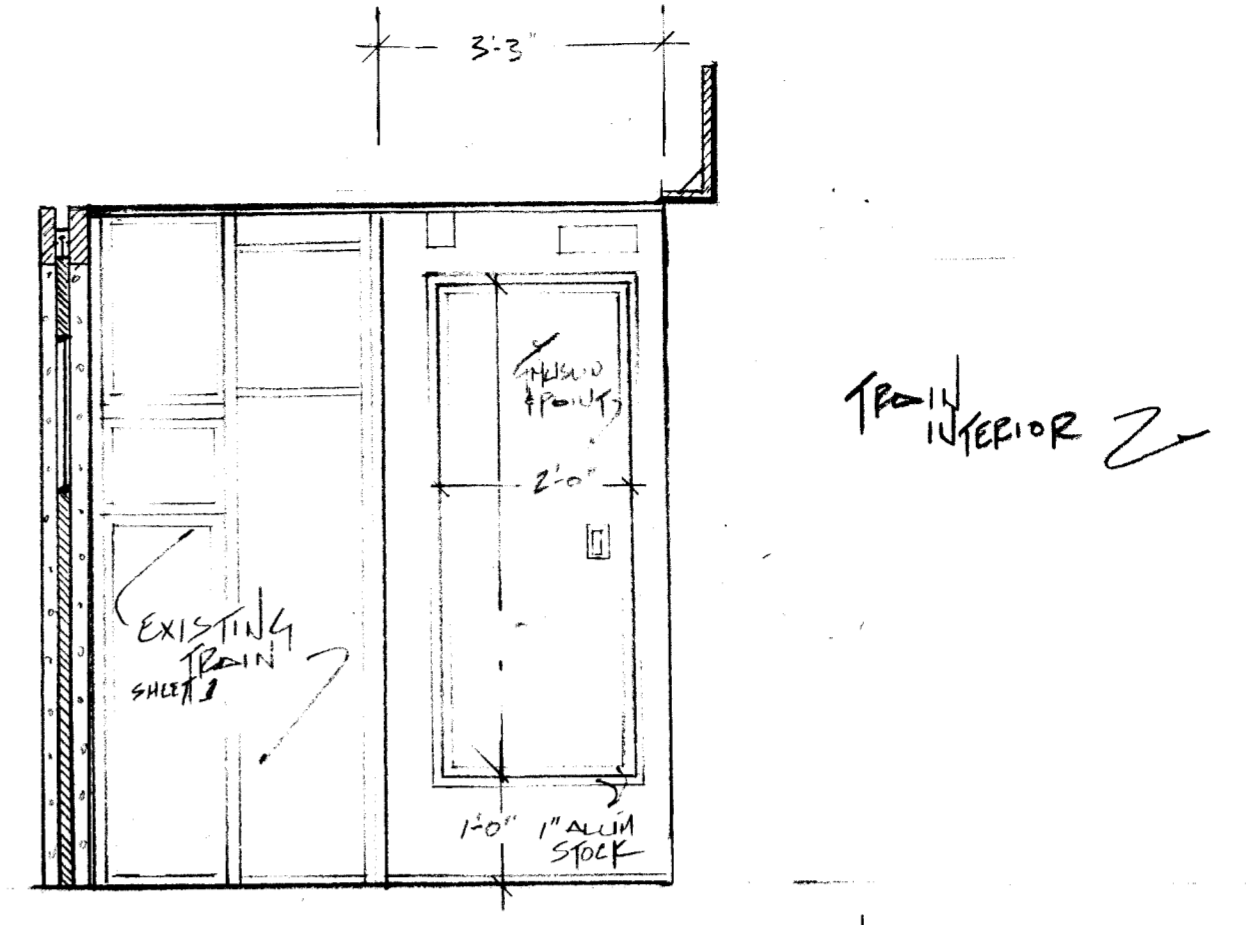

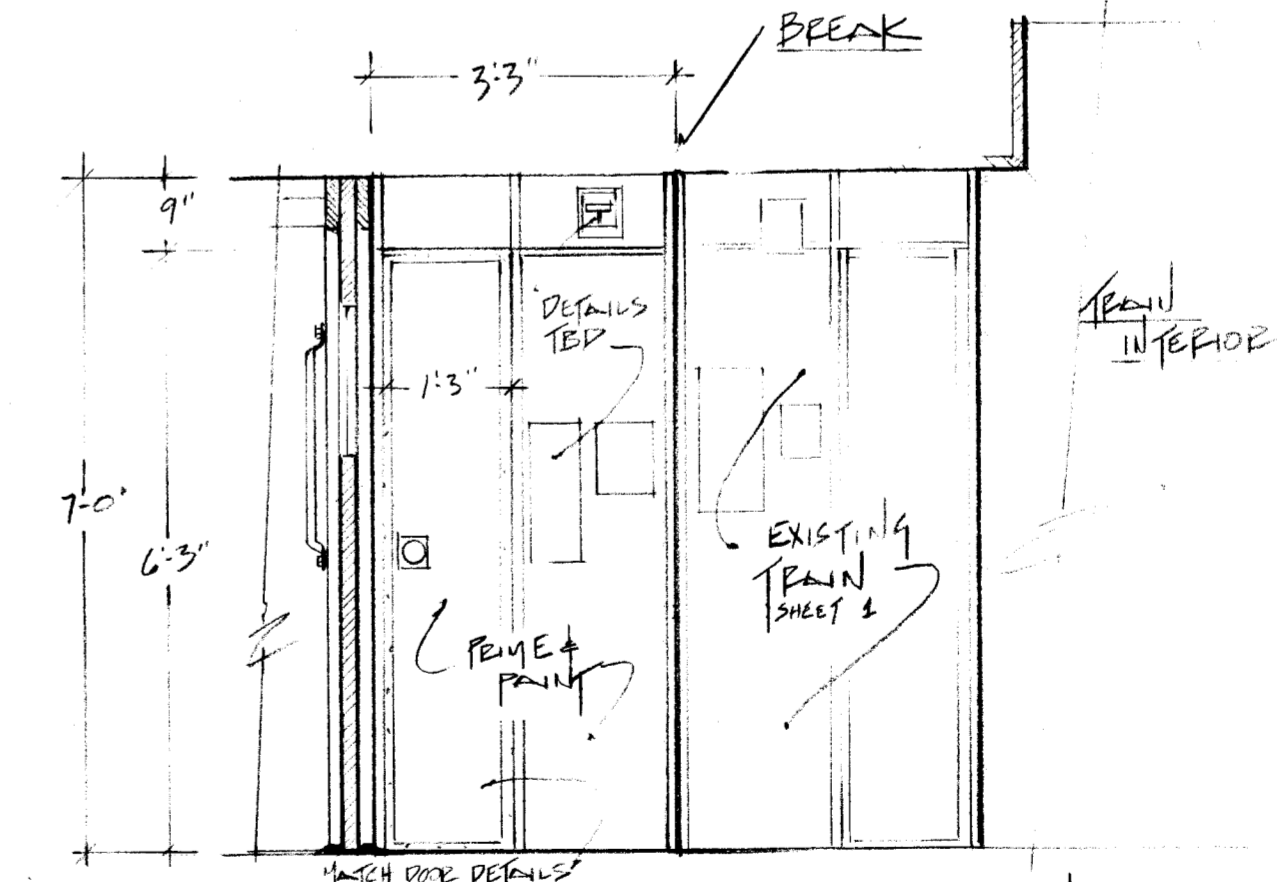
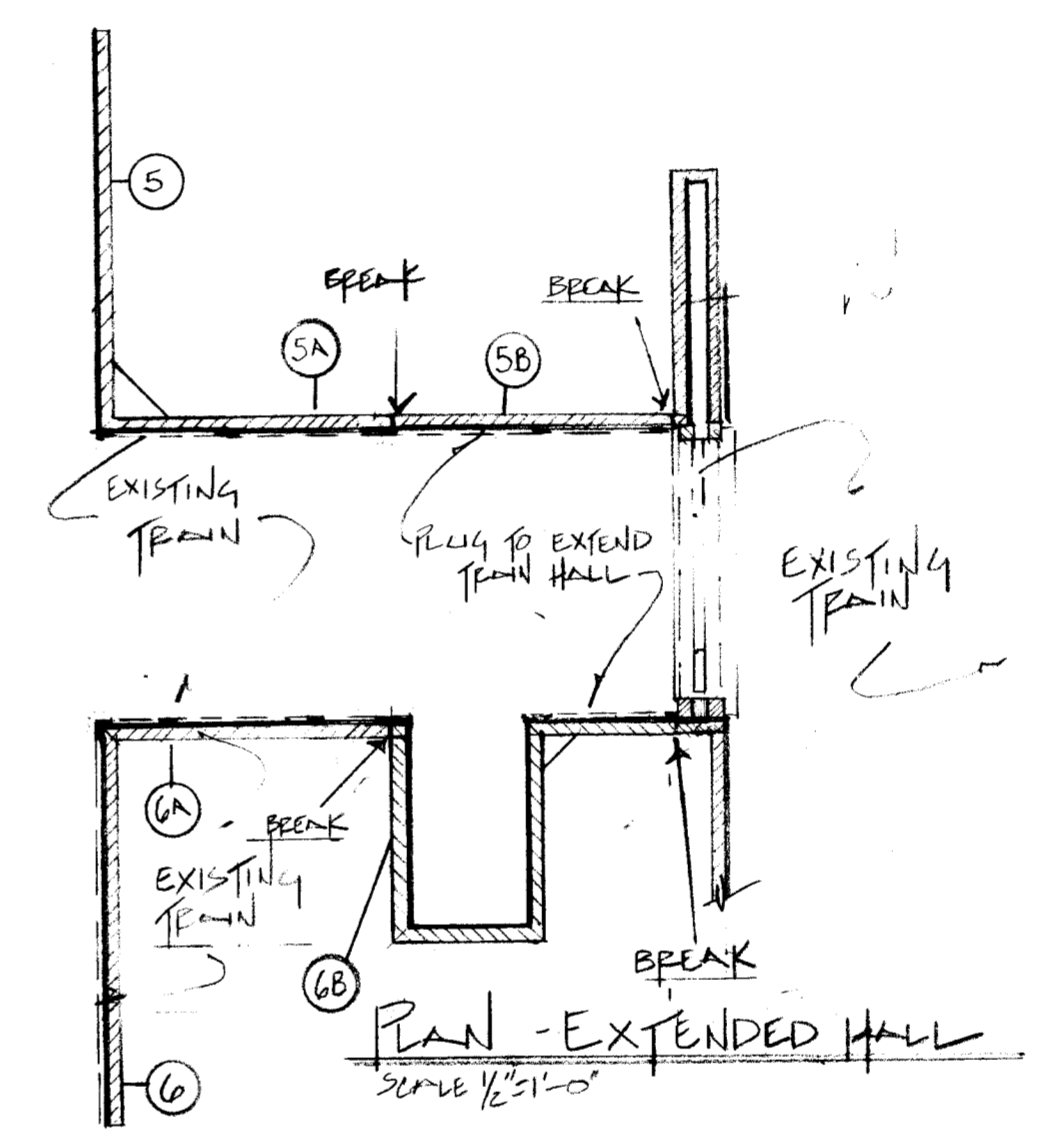

ELEVATION - EXTENDED HALL
SCALE 1/2"=1'-0"



ELEVATION TRUE VIEW ② - EXTENDED HALL
SCALE 1/2"=1'-0"

REVISED

UNION STAMP  S D 393 SCENIC DESIGN SIGNATURE: [Signature]	AMERICAN BROADCASTING COMPANIES 		DRAWING NO.
	PROD: ONE LIFE TO LIVE	STUDIO TV 17	2
SET: PASSENGER TRAIN INT	SCALE: NOTED	DEL. DATE: 3/31/00	OF 2
DRAWN: DATE: 2/23/00	DESIGNER: ROGER MOONEY	PROD. DATE:	DRAFTSMAN: H.P. FARMER

2nd □ REVISION
1st □ REVISION